



ACDIV-2019-18

May 2019

Beam-Based Measurements on Two ± 12.5 kV Inductive Adders, together with Striplines, for CLIC Damping Ring Extraction Kickers

J. Holma, M.J. Barnes, M. Carlà, N. Catalán Lasheras, Y. Papaphilippou, U. Iriso, Z. Martí, F. Pérez, M. Pont

Abstract

The CLIC study is investigating the technical feasibility of an electron-positron linear collider with high luminosity and a nominal centre-of-mass energy of 3 TeV. Pre-damping rings and damping rings (DRs) will produce ultra-low emittance beam with high bunch charge. The DR kicker systems, each of which consists of a set of striplines and two inductive adders, must provide extremely stable field pulses. The DR extraction kicker system is the most demanding: specifications require a field uniformity within $\pm 0.01\%$ and pulses up to 900 ns flat-top duration, at ± 12.5 kV and 309 A, with ripple and droop of not more than $\pm 0.02\%$ (± 2.5 V), with respect to a reference waveform. Two prototype inductive adders have been designed and built at CERN, and have been tested with prototype striplines installed in the storage ring of the ALBA Synchrotron Light Source, in Spain. The stability of the kicker system, including the modulators, has been evaluated from the beam-based measurements and is reported in this paper.

Accelerator Division
Alba Synchrotron Light Source
c/ de la Llum, 2-26
08290 Cerdanyola del Valles, Spain

BEAM-BASED MEASUREMENTS ON TWO ± 12.5 KV INDUCTIVE ADDERS, TOGETHER WITH STRIPLINES, FOR CLIC DAMPING RING EXTRACTION KICKERS

J. Holma^{†1}, M.J. Barnes, M. Carlà, Y. Papaphilippou, N. Catalan Lasheras
 CERN, Geneva, Switzerland

M. Pont, F. Perez, Z. Martí, U. Iriso, CELLS ALBA, Barcelona, Spain

¹also at CELLS ALBA, Barcelona, Spain

Abstract

The CLIC study is investigating the technical feasibility of an electron-positron linear collider with high luminosity and a nominal centre-of-mass energy of 3 TeV. Pre-damping rings and damping rings (DRs) will produce ultra-low emittance beam with high bunch charge. The DR kicker systems, each of which consists of a set of striplines and two inductive adders, must provide extremely stable field pulses. The DR extraction kicker system is the most demanding: specifications require a field uniformity within $\pm 0.01\%$ and pulses up to 900 ns flat-top duration, at ± 12.5 kV and 309 A, with ripple and droop of not more than $\pm 0.02\%$ (± 2.5 V), with respect to a reference waveform. Two prototype inductive adders have been designed and built at CERN, and have been tested with prototype striplines installed in the storage ring of the ALBA Synchrotron Light Source, in Spain. The stability of the kicker system, including the modulators, has been evaluated from the beam-based measurements and is reported in this paper.

INTRODUCTION

To achieve high luminosity at the interaction point of CLIC [1], it is essential that the beams have very low transverse emittance: the Pre-Damping Ring (PDR) and Damping Ring (DR) damp the beam emittance to extremely low values in all three planes. Stripline kickers are required to inject beam into and extract beam from the PDRs and DRs [2]. Jitter in the magnitude of the kick waveform causes beam displacement at the interaction point [3]. Hence, in particular, the DR extraction kicker must have excellent pulse stability (i.e. flatness).

The full-scale prototype of the CLIC DR extraction kicker system, including striplines and two pulse modulators developed at CERN, have been installed and tested with beam in the ALBA Synchrotron Light Source. Results of the beam-based measurements on the stability of the longitudinal field, i.e. the sum of the integrated electric and magnetic fields, of the kicker system are reported here.

SPECIFICATIONS

The specifications for the CLIC DR extraction kicker systems are shown in Table 1 [1]. Design specifications for both a 1 GHz and 2 GHz RF system were proposed: both require that the DR extraction modulator produces pulses of 12.5 kV, with $\pm 0.02\%$ stability (pulse flatness) and $\pm 0.01\%$ repeatability for the kick field [1]. The 2 GHz specifications require a 160 ns duration flat-top [1]. The

1 GHz specifications call for a burst of two 160 ns duration pulses with 580 ns between the end of the flat-top of the first pulse and the beginning of the flat-top of the second pulse. This can also be fulfilled with a single 900 ns, continuous, flat-top pulse.

Table 1: Specifications for the CLIC DR Extraction Kicker

Deflection angle	1.5 mrad (at 2.86 GeV)
Voltage	± 12.5 kV
Current	± 309 A
Flat-top duration	160 900 ns
Impedance	40.5 Ω (odd-mode) 50 Ω (even-mode)
Flat-top stability	$\pm 0.02\%$

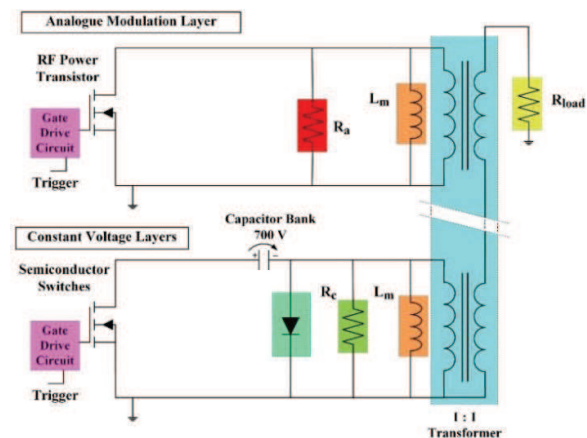

Figure 1: Schematic of an inductive adder with a single constant voltage layer and an analogue modulation layer.

INDUCTIVE ADDERS

An inductive adder (Fig. 1) is a solid-state modulator, which can provide relatively short and precise pulses, and hence it has been selected as the most promising means of achieving the specifications for the DR kickers [4]. An early reference about design principles of an inductive adder is given in [5] and an extensive summary of previous developments of inductive adders at Lawrence Livermore National Laboratory is given in [6], with examples of using modulation techniques for trimming output waveforms. More recent research on inductive adders, also called inductive voltage adders or linear transformer drivers in the literature, have been carried out for Pockels Cells drivers for the National Ignition Facility [7], fast kicker systems at

[†]janne.holma@cern.ch
 Work supported by the CLIC Project

Lawrence Berkeley National Laboratory [8] and industrial applications of pulsed power [9].

In total five prototype inductive adders for the CLIC DR kicker systems have been designed and built at CERN. The reasoning for choosing the main components of the prototype inductive adders has been given in [10, 11]. Operation of the passive and active modulation layers has been verified with measurements in [11, 12]. Evaluation of magnetic cores for the full-scale, 12.5 kV, prototype inductive adders was presented in [13]. Two papers [14, 15] presented measurements on the first 20-layer, full-scale, prototype inductive adders, at up to 10 kV, with analogue modulation applied to generate either a flat-top pulse or a controlled decay waveform. Recently, two full-scale prototypes have been tested up to ± 12.5 kV [16].

STRIPLINE KICKER

A prototype stripline kicker for the CLIC DR extraction kicker system has been designed and built [2]. Simulation of the striplines have shown that, in order to achieve the required stability (flatness) for the total of the deflecting magnetic and electric fields, the waveform for driving the striplines should be a “controlled decay waveform”, as shown in [17], instead of a “flat-top” pulse. Hence, the shape of the inductive adder output waveform must be compared to a simulated, optimally shaped, pulse waveform instead of a flat-top pulse. Characterisation of the prototype striplines, including beam-based measurements of longitudinal and transverse beam coupling impedance and transverse field homogeneity, were carried out at ALBA Synchrotron Light Source in 2018 [18-20].

MEASUREMENTS

Measurement Set-up

The prototype stripline kicker was installed in the ALBA Storage Ring, in a 4 m long straight section. The two prototype inductive adders, one with positive polarity and the other with negative polarity, were installed in the tunnel of the Storage Ring, and connected to each stripline with 3.6 m of high-voltage coaxial cable (Fig. 2). Each stripline was terminated with a 40.5Ω load, connected using 2 m of coaxial cable. RF amplifiers for the analogue modulation layers, low-voltage power supplies and trigger amplifiers for the inductive adders were installed in the tunnel. The high-voltage power supplies and signal generators for supplying the control signal for the analogue modulation layer were installed in the service area, outside of the tunnel.

Principle of Measurements

Measurements have been carried out with a single beam bunch with an intensity of ~ 3 mA. The kick amplitude was obtained from the amplitude of the betatron motion measured using 120 beam-position monitors (BPMs), over 400 turns. The striplines were used to kick the beam vertically at 3.125 Hz and the kick field flat-top duration was 800 ns.

Timing of the kicker pulse was changed with respect to the passing bunch, to scan the kick field pulse in time. Each field pulse measurement consists of a scan, of the

kick delay with respect to the beam, over 25 points spaced in time by 8 ns. This allowed to sample the kick field for 192 ns with a 125 MHz effective sampling frequency. Each measurement point was sampled 50 times, to increase resolution of the measured kick. For each measured kick waveform, the kick field was scanned twice, from the beginning of a flat-top to the end and then backwards. Each scan lasted 30-45 minutes. The measurements shown in this paper were carried out at ± 5 kV stripline voltages: the maximum voltage was limited by machine parameters and repeatability requirements of the measurements.

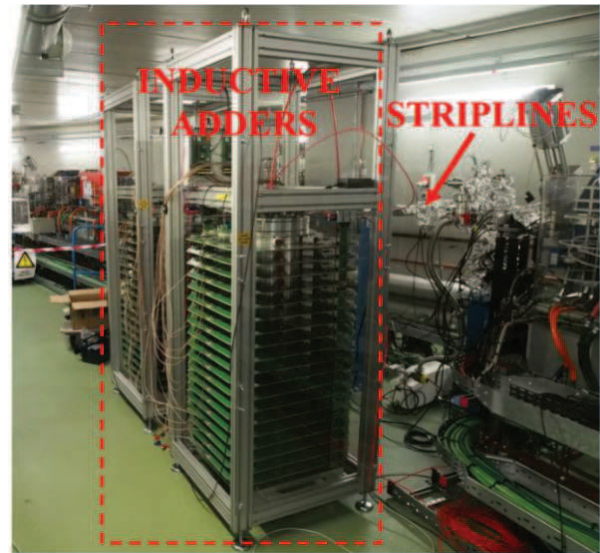

Figure 2: The CLIC DR prototype inductive adders and striplines installed in the ALBA Storage Ring.

Calibration Measurements

It was observed that the beam current decay during a single measurement scan, i.e. in 30-45 minutes, had a significant effect upon the measured kick. This effect was studied by measuring repeatedly the kick strength, at a given time point of the field pulse, while the beam current naturally decayed. A 3% variation of the measured kick was observed due the beam current dropping from 3.15 mA to 2.45 mA over a period of ~ 40 minutes. Establishing the relationship between beam current and measured kick amplitude made it possible to normalize properly the subsequent measurements and remove the dependency on the unavoidable beam current drop experienced during the acquisitions.

The calibration measurements allowed also to understand the noise and stability of the set-up. The mean error of the kick amplitude, i.e. the repeatability of measurements for a single time point of the flat-top, for each set of 50 samples, was within ± 0.01 %. However, the mean kick amplitude had a variation of 0.04 % (rms) during the full scan from the maximum to minimum beam current. The recorded stripline current waveforms of the calibration measurements showed corresponding variations and this could have been caused e.g. by thermal drift of the high-voltage DC power supplies.

Content from this work may be used under the terms of the CC BY 3.0 licence (© 2019). Any distribution of this work must maintain attribution to the author(s), title of the work, publisher, and DOI

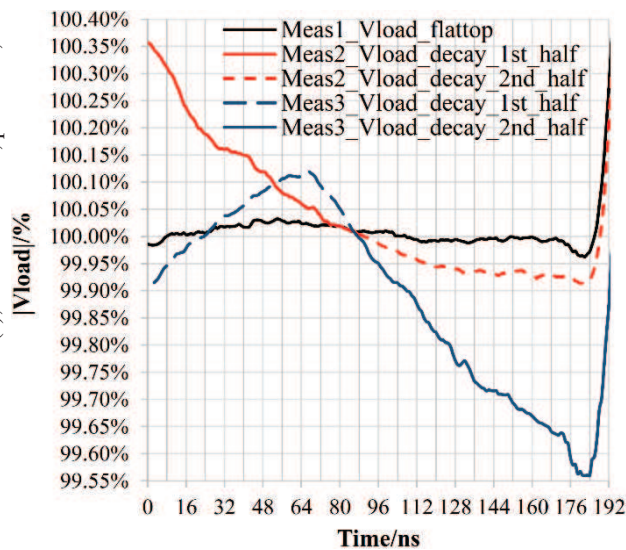

Figure 3: Three measured, normalised, load voltage waveforms at ± 5 kV. The flat-top waveform (black) is an average of 1k measured pulses, the other waveforms are averages of 400 pulses.

Measurements of Kick Field

The first two scans of the longitudinal kick field were carried out by applying a “flat-top” voltage waveform for the striplines (Fig. 3, black). According to simulations presented in [17], this was expected to give a kick field, which has an upward slope (Fig. 4, black). The second set of scans was with “controlled decay voltage waveforms” from inductive adders (Fig. 3, red, solid and short dash). This was expected to yield a “flat-top” kick field [17] (Fig. 4, red, solid and short dash). However, in this measurement, it was found that the dynamic range of the analogue modulation layers was able to generate a decay waveform with adequate amplitude change only from 0 ns to 88 ns and not during the full 192 ns flat-top duration. Therefore, a 3rd measurement was carried out by applying the decay waveform during the 2nd half of the voltage waveform (Fig. 3, blue, long dash and solid), which produced a flat-top kick field for the 2nd half of the measured kick field, from 88 ns to 184 ns (Fig. 4, blue, long dash and solid).

Analysis of Results

The deviation of the measured kick waveforms (Fig. 4) from a 4th order polynomial fit (1st measurement) or from an ideal flat-top (2nd and 3rd measurements, 1st or 2nd half, respectively) is approximately $\pm 0.03 \dots 0.04$ %. The deviation of the measured voltage waveforms (Fig. 3), from an ideal flat-top pulse (1st measurement) or from a 4th order polynomial fit, in the case of a decay voltage waveform (2nd and 3rd measurements, 1st or 2nd half, respectively), is approximately $\pm 0.02 \dots 0.03$ %. Hence, the fluctuations of the kick waveforms, measured with BPMs (Fig. 4), and waveforms from the striplines, measured with a current transformer and an oscilloscope (Fig. 3), are consistent.

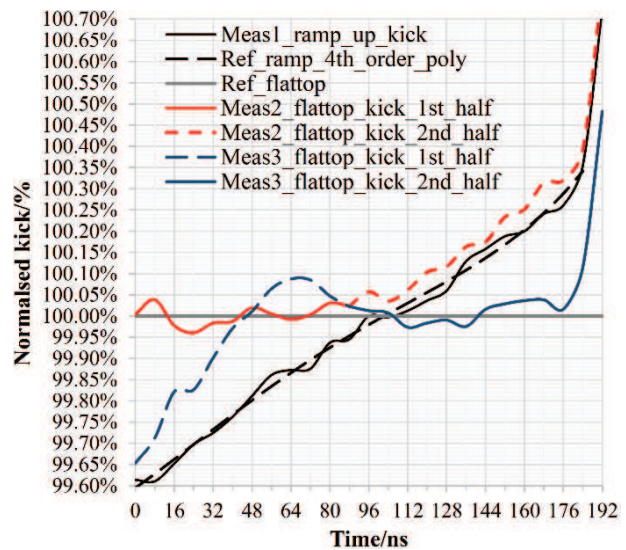

Figure 4: Three measured, normalised, kick waveforms and reference waveforms at ± 5 kV.

In the case of a flat-top voltage waveform, the measured ramp-up kick waveform has an average gradient of 0.62 % per 160 ns (Fig. 4, black). This is consistent with a flat-top kick, where the generated decay voltage waveforms had an average gradient of 0.65 % per 160 ns (Fig. 3, red, solid, and blue, solid). The simulated kick waveform, for a flat-top voltage waveform, has an average gradient of ~ 0.3 % per 160 ns, over the first 160 ns and ~ 0.1 % per 160 ns over the last 160 ns [17]. The reason for the differences between the gradients, for the measured and simulated kick waveforms, is not presently understood.

SUMMARY AND ON-GOING WORK

The beam based measurements on the CLIC DR extraction kicker prototype inductive adders and striplines have confirmed that ± 0.02 % stability specifications are very probably achievable. The measured longitudinal kick field stability, for the entire prototype kicker system, was $\pm 0.03 \dots \pm 0.04$ % over 160 ns. The measured stability of the kick fields and voltage waveforms were consistent with one another and also with earlier laboratory measurements of the prototype inductive adders, which demonstrated ± 0.02 % up to 10 kV [15]. The measured stabilities are an order or magnitude better than in typical kicker systems used for accelerators. However, in all measurements shown in this paper, averaging has been applied to increase the resolution of the measured kick and voltage: the stability of a single kick or voltage waveform was not measured here. The measurements reported here complete the characterisation of the CLIC DR extraction kicker inductive adders and striplines, together with the feasibility studies of the CLIC DR extraction kicker systems [18-20].

In the future, one of the prototype inductive adders will be equipped with eight additional layers to test the feasibility of a combined 12.5 kV/17.5 kV inductive adder. This could be used as both an extraction and dump kicker modulator for CLIC DRs and is also expected to meet the specifications for the CLIC DR injection and the CLIC PDR injection kicker modulators [1].

REFERENCES

- [1] M. Aicheler (ed.) *et al.*, "A multi-TeV Linear Collider based on CLIC technology: CLIC Conceptual Design Report", CERN-2012-007.
- [2] C. Belver-Aguilar, M. J. Barnes, and L. Ducimetière, "Review on the effects of characteristic impedance mismatching in a stripline kicker", in *Proc. IPAC'16*, Busan, Korea, May 2016, paper THPMW034, doi:10.18429/JACoW-IPAC2016-THPOR033
- [3] Y. Papaphilippou *et al.*, "Conceptual design of the CLIC damping rings", in *Proc. IPAC'12*, New Orleans, USA, May 2012, paper TUPPC086, pp. 1368-1370.
- [4] J. Holma, M.J. Barnes, and S.J. Ovaska, "Preliminary design of the pulse generator for the CLIC DR extraction system", in *Proc. PPC'11*, pp. 1353-1358, Chicago, USA, June 2011.
- [5] C. Burkhardt, L. Ahle, J.R. Bayless, R. Hanks and E. Kelm, "MIA modulator for the LLNL "small recirculator" experiment", *Nucl. Instr. Meth., Phys. Res. A*, 464, pp. 452-456, 2001.
- [6] E.G. Cook *et al.*, "Solid-state modulator R&D at LLNL", Int. Workshop on Recent Progress of Induction Accelerators, Tsukuba, Japan, Oct. 2002.
- [7] F. Barbosa *et al.*, "Development of solid-state drivers for the NIF plasma electrode Pockels cell", in *Proc. IPMHVC'08*, pp. 109-112, Las Vegas, NV, USA, May 2008.
- [8] W.L. Waldron, J.E. Galvin and W.B. Ghiorso, "The design and testing of an inductive voltage adder for ALS-U kicker magnets", in *Proc. IPMHVC'16*, pp. 176-178, San Francisco, CA, USA, July 2016.
- [9] K. Okamura, "Solid-state pulsed power and industrial applications in Japan", *4th Asian Forum for Accelerators and Detectors*, BINP, Novosibirsk, Russia, Feb. 2013.
- [10] J. Holma, and M.J. Barnes, "Preliminary design of an inductive adder for CLIC damping rings", in *Proc. IPAC'11*, San Sebastian, Spain, Sept. 2011, THPO032, pp. 3409-3411.
- [11] J. Holma, "A Pulse power modulator with extremely flat-top output pulses for the Compact Linear Collider at CERN", Ph.D. Thesis, Aalto University publication series, Doctoral Dissertations 196/2015, Helsinki, Finland, 2015. Available on-line: <https://cds.cern.ch/record/2130258/files/CERN-THESIS-2014-359.pdf>
- [12] J. Holma, and M.J. Barnes, "The prototype inductive adder with droop compensation for the CLIC kicker systems", *IEEE Trans. Plasma Sci.*, Vol. 42, No. 10, Oct. 2014, pp. 2899-2908.
- [13] J. Holma, M.J. Barnes, and L. Ducimetière, "Measurements on magnetic cores for inductive adders with ultra-flat-top output pulses for CLIC DR kickers", in *Proc. IPAC'16*, Busan, Korea, May 2016, THPMW032, doi:10.18429/JACoW-IPAC2016-THPMW032
- [14] J. Holma, M. J. Barnes, and A. Ferrero Colomo, "Demonstration of Feasibility of the CLIC Damping Ring Extraction Kicker Modulators", in *Proc. IPAC'18*, Vancouver, BC, Canada, Apr.-May 2018, WEPMF077.
- [15] J. Holma, M.J. Barnes, "Prototype Inductive Adders With Extremely Flat-Top Output Pulses for the Compact Linear Collider at CERN", *IEEE Trans. Plasma Sci.*, Vol 46., No 10, Oct. 2018.
- [16] J. Holma, M.J. Barnes, M. Pont, A. Chmielinska, "Laboratory Measurements on two +/-12.5 kV Inductive Adders with +/-0.02% Waveform Stability for CLIC Damping Ring Extraction Kickers", presented at the 10th International Particle Accelerator Conf. (IPAC'19), Melbourne, Australia, May. 2019, paper THPRB073, this conference.
- [17] C. Belver-Aguilar and M.J. Barnes, "Transient studies of the stripline kicker for beam extraction from CLIC damping rings", in *Proc. IBIC'16*, Barcelona, Spain, 2016, MOPG05, pp. 35-38, doi:10.18429/JACoW-IBIC2016-MOPG05
- [18] M. Pont *et al.*, "The stripline kicker prototype for the CLIC damping rings at ALBA: installation, commissioning and beam characterisation", in *Proc. IPAC'18*, THPMF013, pp. 4062-4065.
- [19] F. Perez, "Field homogeneity measurements with beam of the CLIC Stripline at the ALBA Storage Ring", presentation at CLIC Workshop 2019, CERN, Geneva, Switzerland, Jan. 2019.
- [20] U. Iriso *et al.*, "Commissioning of the CLIC extraction kicker at ALBA", presentation at Beam Tests and Commissioning of Low Emittance Storage Rings Workshop, Karlsruhe, Germany, Feb. 2019.