



ACDIV-2019-09

May 2019

## **New 50KW SSPA Transmitter for the Alba Booster**

P. Solans, B. Bravo, J.R. Ocampo, F. Perez, A. Salom, F. Sierra, J. Lluch, C. Rosa, D. Iriarte, E. Ugarte, I. Fernández, A. Mellado, J.V. Balboa

### Abstract

ALBA is a 3rd generation synchrotron light source located in Cerdanyola del Vallès, Barcelona, in operation since 2012. The RF system consists of six normal conducting cavities in the storage ring, fed with IOT based transmitters that are able to provide up to 3.6 MV to the beam. The booster accelerator counts with one single 5- cell cavity. This cavity was used to be fed with an IOT based transmitter also until August 2018, when a solid state power amplifier (SSPA) was installed replacing the old transmitter. This paper covers the design, test and operation of the new SSPA based RF transmitter for the ALBA booster\*.

Accelerator Division  
Alba Synchrotron Light Source  
c/ de la Llum, 2-26  
08290 Cerdanyola del Valles, Spain

# NEW 50 KW SSPA TRANSMITTER FOR THE ALBA BOOSTER

P. Solans, B. Bravo, J.R. Ocampo, F. Perez, A. Salom, CELLS – ALBA synchrotron, Cerdanyola del Vallès, Spain

F. Sierra, J. Lluch, C. Rosa, D. Iriarte, E. Ugarte, I. Fernández, A. Mellado, J.V. Balboa, BTESA Broad Telecom, Madrid, Spain

## Abstract

ALBA is a 3<sup>rd</sup> generation synchrotron light source located in Cerdanyola del Vallès, Barcelona, in operation since 2012. The RF system consists of six normal conducting cavities in the storage ring, fed with IOT based transmitters that are able to provide up to 3.6 MV to the beam. The booster accelerator counts with one single 5-cell cavity. This cavity was used to be fed with an IOT based transmitter also until August 2018, when a solid state power amplifier (SSPA) was installed replacing the old transmitter. This paper covers the design, test and operation of the new SSPA based RF transmitter for the ALBA booster\*.

## INTRODUCTION

Telecommunications industry is pushing the solid state technology towards higher performance and behaviour: New transistors, with higher drain voltages and new semiconductor materials, are able to provide more power at higher efficiencies [1]. This means, that a lower number of active devices are needed to get the same amount of power, which decreases the price of these kind of high power amplifiers.

This technology is attractive for synchrotrons and particle accelerators, due to the advantage they present in front of the inductive output tubes (IOT's) or other vacuum tubes amplifiers, such as klystrons [2]. Neither high voltage nor vacuum are needed and they present a better redundancy due to the large number of devices used in the designs, which eliminates a single point of failure in the amplification stage.

Modularity allows the compensation of the power drop after a module's failure, avoiding the stop of the operation, and therefore, increasing the Mean Time Between Failure. The Mean Time To Recovery also decreases due to the fast replacement and off line reparation of a faulty module.

Due to all these advantages, a Call for Tender was published in order to replace the booster tube based transmitter by a new SSPA. The Call for Tender included design, construction, transportation, and installation in the facility, as well as the personal training.

\* This project is co-funded by the European Regional Development Fund of the European Union.



## DESIGN

The new SSPA RF transmitter for the ALBA booster is based in a 50 V NXP MOSFET transistor. Up to 96 of these devices are distributed in 12 modules of 8 transistors each one providing a total power of 48 kW (P2dB) at 500 MHz and more than 78 dB of power gain.

Drive is split trough three 90° hybrid connected in cascade that provide three branches of amplification. Every branch is then split into four channels using several Wilkinson dividers. Finally, drive goes into the amplification module. No amplification has been performed until this stage.

Two pre-amplification stages can be found before the final splitting towards the transistors inside the modules. They form balanced class-AB amplifier pairs. The power of these pairs inside the module is added using a 4-port Gysel combiner that provides adaptation and isolation to the transistors [3]. The total power of a single module is up to 5 kW, and again, four of these modules are added using a larger 4-port Gysel combiner. Topology of the combiner is shown in Fig. 1.

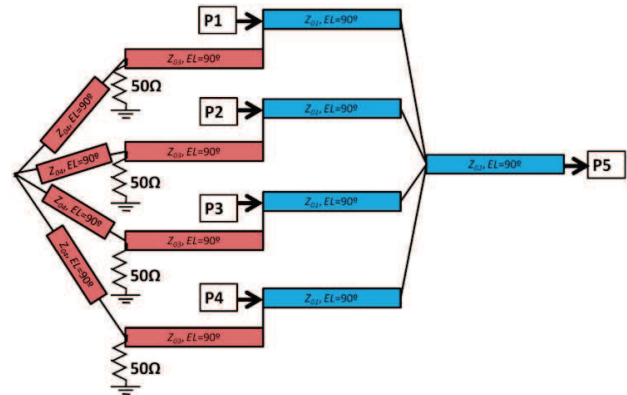

Figure 1: Gysel Combiner topology.

Table 1 shows the performance of such a combiner. Note the good adaptation and the high isolation between input ports.

Table 1: Combiner Main Characteristics

Port	Return loss [dB]	Isolation [dB]	Transmission [dB]
1	-34.2	-40.0 (to P2)	-6.04
2	-25.7	-36.4 (to P3)	-5.95
3	-33.8	-36.7 (to P4)	-6.16
4	-30.2	--	-6.13
5	-41.3	--	--

Content from this work may be used under the terms of the CC BY 3.0 licence (© 2019). Any distribution of this work must maintain attribution to the author(s), title of the work, publisher, and DOI

Finally, two large 90° hybrids are used for the total combination of power. All the stages are dimensioned for the power handling: the size of the microstrip and the coaxial lines and also the isolation loads.

Figure 2 shows the complete architecture of the SSPA transmitter.

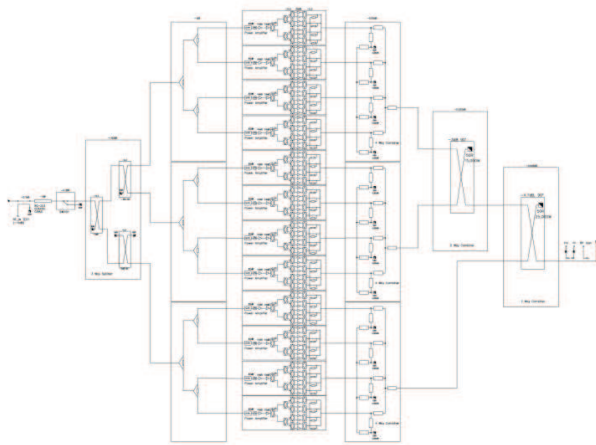

Figure 2: SSPA schematic.

The amplification is completely done inside the modules and they are considered as a complete and independent amplifier. Every module has a control board to monitor the forward and reverse power as well as the transistors current consumption, among others. If some of the measurements are outside the operation ranges, the module can be switched off, allowing the rest of the modules to provide the extra power needed to reach the desired amount of voltage in the cavity.

The module also hosts up to three power converters that provide the electrical power to the amplifier. This large number of supplies, 36 in total, leads to a high redundancy so that the transmitter is able to provide more than 40 kW with a 5% of the power supplies switched off, assuring the operation of the ALBA booster.

SSPA is cooled down with a primary circuit of deionized water and no hot air is delivered into the room. The total consumption is 100 l/min. Modules are connected to the main cooling line via quick fittings, allowing a fast dismantling. The transmitter measures the total water flow and thermal switches have been placed near the amplification stages, the isolation loads, and the combiners in order to supervise the transmitter's temperature.

The modules can be hot swapped, i.e. they can be removed even when the SSPA transmitter is providing power. Interfaces such as RF coaxial lines, water cooling, AC supply, and communications are made so that allows a fast and controlled disconnection of a complete module.

The transmitter is able to work in CW or pulsed mode and it is synchronized with the LLRF system, in order to measure at the top of the pulse.

### FAT AND SAT

Factory acceptance test was successfully performed in the vendor's site in July 2018. Site acceptance test was

done at ALBA after the installation in the service area, in August 2018. Both tests demonstrate the appropriate behaviour of the SSPA transmitter and the measurements were within the specifications. Table 2 summarises the main operation parameters measurement.

Table 2: SSPA Transmitter Main Parameters

Parameter	Value
Fundamental frequency	499.654 MHz
Bandwidth	> 2 MHz
Nominal power (P1dB)	48 kW
PAE at P1dB	60.5 %
Gain at P1dB	77 dB
Harmonic content at P1dB	< 40 dBc
SNR within BW	> 72 dBc
Spurious within ± 20 MHz	< 60 dBc
Phase compression	< 10°
Phase noise	< 0.5°

Pulsed mode was also tested in the SSPA and all measurements were within specifications: 50 ns of maximum rise and fall time and less than 0.25 dB of pulse ripple.

Figure 3 shows the power and gain measurements for the complete transmitter.

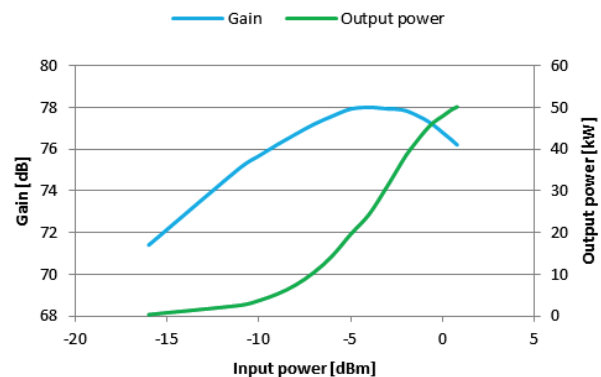

Figure 3: SSPA transmitter output power and gain.

Maximum gain is 78 dB at 31 kW and maximum power is 50 kW with a compression of 1.8 dB.

Figure 4 shows the power and gain of a single module.

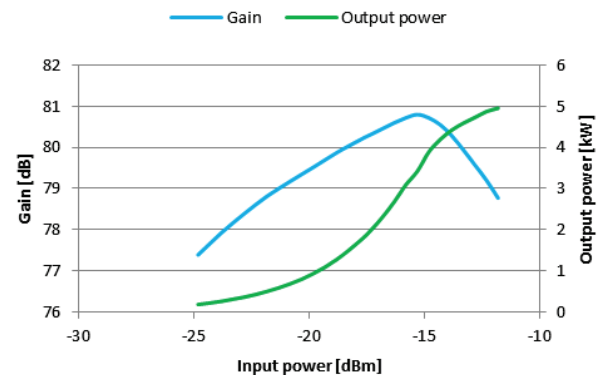

Figure 4: SSPA transmitter output power and gain.

The maximum gain of a single module is almost 3 dB greater than the one of the whole transmitter. This is due to the losses in splitting and combining stages as well as to amplitude and phase mismatches in the combiners.

The required drive to get the maxim output power is 13.6 dB less than the one needed for the case of the complete transmitter. 12 dB corresponds to the four level power splitting structure intrinsic loss and 1.6 dB to the insertion losses of the splitters and cables.

Redundancy (and hot swapping) of the transmitter was tested by disconnecting a module while power was being delivered. After the module's removal, transmitter continued operation with a loss of power following equation 1:

$$P = P_o \left( \frac{N - M}{N} \right)^2 \quad (1)$$

Where P is the final power, P<sub>o</sub> is the power delivered before the disconnection, N is the total number of available modules, and M is the number of disconnected modules. Table 3 shows the result of disconnecting a single module.

Table 3: One Module Failure Power Drop

Modules	Output Power [kW]
N=12, M=0	48.0
N=12, M=1	40.4

Table 4 shows the case where two transistors inside a module are disconnected. Equation 1 can also be applied.

Table 4: Two Transistors Failure Power Drop

Modules	Output Power [kW]
N=12, M=0	48.0
N=12, M=1	40.4

Note that gain drop caused by some broken module, transistors, or power supplies can be compensated by the LLRF control loop that just provides more drive to get the same amount of output power.

Final assembly can be seen in Fig. 5.



Figure 5: SSPA transmitter for the ALBA booster.

## OPERATION

The SSPA transmitter was installed in August 2018 during a long shutdown period. Since then, the equipment has been operating without major problems and only some minor incidences have arisen. All the failures were located inside the modules, allowing the fast replacement by a spare even when the transmitter was in operation without compromising the performance of the ALBA booster.

We can see the number of incidences, since 2013 that lead to a trip of the transmitter of the booster in Fig. 6.

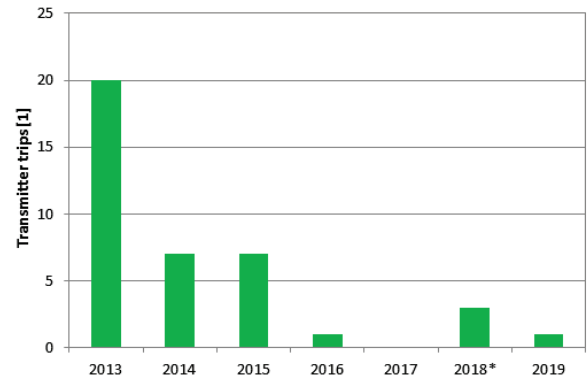

Figure 6: Booster RF transmitter trips.

All the trips occurred in 2018 happened before the installation of the new SSPA transmitter, so just one new trip has been triggered after the installation, in 2019. This single trip event should be compared to the first years of operation of the IOT based transmitter. Even though it looks like a huge improve in performance, and it is actually; it is too early to conclude a better behaviour due to the short time of operation of the transmitter.

## CONCLUSIONS

A 50 kW at 500 MHz SSPA based transmitter has been successfully designed and installed for the ALBA booster. Performance and behaviour of the transmitter fit completely the design parameters.

Same design could be exported to the storage ring transmitters, improving the reliability of the radiofrequency system for the beam, and therefore, increasing the beam availability and the MTBF and MTTR.

## REFERENCES

- [1] Lopez, Nestor & Hoversten, John & Poulton, Matthew & Popovic, Zoya. (2008). A 65-W high-efficiency UHF GaN power amplifier. *IEEE MTT-S International Microwave Symposium Digest*. 65 - 68. 10.1109/MWSYM.2008.4633104.
- [2] J.R. Ocampo *et al.*, "Operational Experience with IOTs at Alba Synchrotron", in *Proc. 9th Int. Particle Accelerator Conf. (IPAC'18)*, Vancouver, BC, Canada, Apr. 4., pp. 2372-2374, doi:10.18429/JACoW-IPAC2018-WEPMF002
- [3] U. H. Gysel, "A New N-Way Power Divider/Combiner Suitable for High-Power Applications," *1975 IEEE-MTT-S International Microwave Symposium*, Palo Alton, CA, 1975, pp. 116-118, doi: 10.1109/MWSYM.1975.1123301