



ACDIV-2017-10

May 2017

FABRICATION AND TESTS OF A RF CAVITY FOR A NOVEL COMPACT SUPERCONDUCTING CYCLOTRON FOR RADIOISOTOPE PRODUCTION

D. Gavela, J. Calero, L. García-Tabarés, P. Gómez, D. López, D. Obradors-Campos, C. Oliver, J.M. Pérez, I. Podadera, F. Toral - CIEMAT
B. Bravo, R. Fos, J.R. Ocampo, F. Pérez, A. Salom, P. Solans - ALBA Synchrotron

Abstract

The AMIT cyclotron will be a 8.5 MeV, 10 μ A, CW, Haccelerator for radioisotope production, including a superconducting, weak focusing, 4 T magnet, allowing for a low extraction radius and a compact design. The cavity is a 60 MHz, quarter wave resonator powered by a modular 8 kW solid state amplifier. The design of the cavity dealt with challenging requirements: high electric fields required by a high voltage (60 kV) on a small gap, a small aperture of the magnet leading to high capacitances and thermal losses and a requirement for a low overall size of the cavity. The fabrication process included high precision machining, soft soldering, laser welding and careful metrologies, which are described together with other technical and practical aspects. The low power tests showed a good agreement with the simulations. The conditioning of the cavity was performed with a 1.1 T magnetic field applied on the central region. It was successfully finished regarding to maximum voltage reached, power losses and temperatures. The cavity was also tested at high power with a constant hydrogen flow injected in the central region (as expected in the cyclotron) with success.

Accelerator Division
Alba Synchrotron Light Source
c/ de la Llum, 2-26
08290 Cerdanyola del Valles, Spain

FABRICATION AND TESTS OF A RF CAVITY FOR A NOVEL COMPACT SUPERCONDUCTING CYCLOTRON FOR RADIOISOTOPE PRODUCTION*

D. Gavela[†], J. Calero, L. García-Tabarés, P. Gómez, D. López, D. Obradors-Campos, C. Oliver, J.M. Pérez Morales, I. Podadera, F. Toral, CIEMAT, Madrid, Spain
B. Bravo, R. Fos, J.R. Ocampo, F. Pérez, A. Salom, P. Solans, ALBA-CELLS Synchrotron, Cerdanyola del Vallès, Spain

Abstract

The AMIT cyclotron will be a 8.5 MeV, 10 μ A, CW, H⁻ accelerator for radioisotope production, including a superconducting, weak focusing, 4 T magnet, allowing for a low extraction radius and a compact design. The cavity is a 60 MHz, quarter wave resonator powered by a modular 8 kW solid state amplifier. The design of the cavity dealt with challenging requirements: high electric fields required by a high voltage (60 kV) on a small gap, a small aperture of the magnet leading to high capacitances and thermal losses and a requirement for a low overall size of the cavity. The fabrication process included high precision machining, soft soldering, laser welding and careful metrologies, which are described together with other technical and practical aspects. The low power tests showed a good agreement with the simulations. The conditioning of the cavity was performed with a 1.1 T magnetic field applied on the central region. It was successfully finished regarding to maximum voltage reached, power losses and temperatures. The cavity was also tested at high power with a constant hydrogen flow injected in the central region (as expected in the cyclotron) with success.

INTRODUCTION

The AMIT accelerator is a compact classical cyclotron for production of isotopes for positron-emission tomography (PET) diagnostics [1]. The conceptual design of its RF cavity had to deal with two fundamental challenges [2]: a high cavity voltage (60 kV) forced by the classical cyclotron concept and a reduced allowed height for the cavity at the central area imposed by the magnet aperture.

The cavity (see Fig. 1) is a quarter wave resonator in horizontal position with the accelerating 180° dee at the end of a copper stem. The cavity is composed of a box (with rectangular section adapted to the space inside the magnet aperture), and a resonator (a larger cylindrical section outside the magnet for achieving the resonance whilst minimizing the thermal losses).

The half of the box where no RF fields are present houses the extraction system, diagnostics and the port for the isotopes producing target.

The stem is mounted on the internal face of the end plate. It has an increasing section size from the dee to the end plate motivated by the higher current near the end plate. The upper and lower walls of the rectangular part of

the cavity are covered by 3-mm liners with the purpose of having a good copper thickness for receiving the impact of the electrons, strongly focused in the vertical direction by the magnetic field, which could otherwise damage a conventional copper coating of a stainless steel surface.

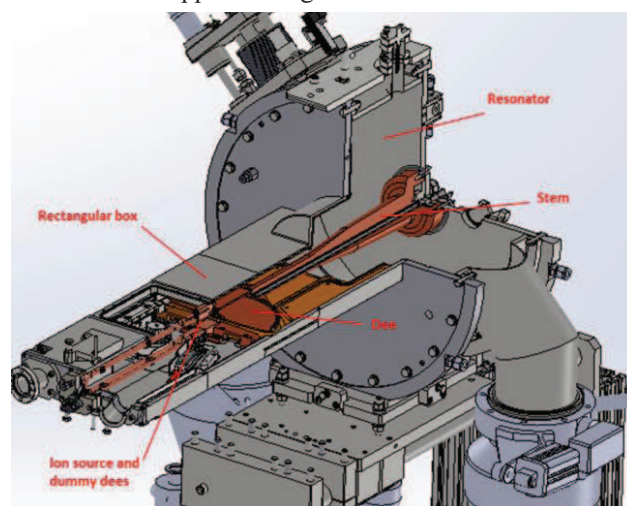

Figure 1: Overview of the cavity.

FABRICATION

The main fabrication steps and procedures are described below. The main challenge of the fabrication process was to guarantee a good relative position between the electrodes for achieving a good quality of the accelerating field, which is not an easy task taking into account that it is determined by the whole chain of tolerances determining the relative position of the parts, starting at the box, going through the resonator and coming back through the stem and dee.

Cavity Shell

The cavity shell is made of five solid 316L stainless steel parts joined by TIG and laser weldings. The selection of the materials and the union procedures were done with the objectives of providing vacuum tightness, minimizing the deformations induced by machining and welding processes and ensuring a minimal magnetization to avoid distortion of the cyclotron's magnetic field quality.

Tolerances of the contact surfaces for the positioning of the different parts were in the order of few hundredths of mm. Additionally, the final machining operations which determine the position of the dummy dees (the fixed elec-

* Work partially supported by the Resolution of the Spanish Ministry of Economy and Competitiveness dated May 22th, 2015

[†] daniel.gavela@ciemat.es

trodes) were performed after all the welding operations for avoiding errors due to deformations induced by them.

The resonator body is performed by cutting a slice from a 316L stainless steel tube, with a final machining of the internal and external diameters. Ports for two diffusion vacuum pumps, two tuners and the pickup probe were TIG welded to this part. The joint between the resonator and the two plates is performed with metal gaskets and bolts.

A 0.1-mm electro-deposited copper coating is applied on the internal surfaces of all the cavity shell parts after all the welding and machining operations.

Stem, Dee and Puller

Three copper parts are joined with bolts and high precision positioning pins (see Fig. 2). To ensure a good heat transfer from the dee to the stem, where the cooling water is located, their contact surfaces are filled with a Sn-Ag soldering filler deployed with local heat application.

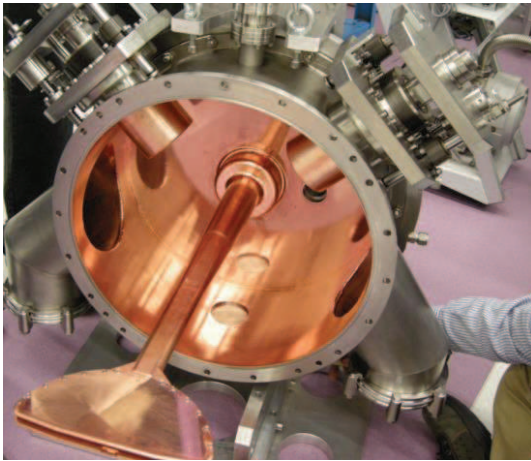

Figure 2: Stem and dee mounted on the resonator.

The puller has a complex 3D geometry determined from an optimization process for achieving the correct accelerating fields whilst minimizing the peak electric field. It is fabricated from four micro machined copper parts sandwiched between the dee plates and forced into its position by a small brass spring that allows the extraction of the puller just by pulling without the need of any bolts.

Strict tolerances (again of few hundredths of mm) were applied to all these copper parts. Maximum roughness was set at Ra 0.8 at all surfaces seeing RF currents. At the areas where the highest peak electric fields were expected in the dee front and puller (up to 24 MV/m, 2.6 x Kilpatrick) stricter surface finish was required.

Liners

These copper parts, covering the internal upper and lower surfaces of the box, were manufactured by soft-soldering of several 3-mm thickness copper parts clamped on a special tooling providing the appropriate shape and dimensions (see Fig. 3).



Figure 3: Liner clamped on the tooling during the soldering process of the cooling tubes.

Other Parts

Two tuning plungers moved by stepper motors, an input coupler and a pickup probe were manufactured and assembled to the cavity with techniques that had already been successfully applied to the re-buncher cavities for LIPAc accelerator (IFMIF project), with no major novelty with respect to that cavity [3].

Cooling

The cooling of the end plates, stem, input coupler and tuners are performed with the exact same technique as in [3]. The calculations showed that no cooling was necessary for the resonator main body and so it is cooled just by contact with the other parts of the cavity.

A complex 3D tubing layout was designed for the cooling of the liners. The tubes were bended with a special tooling with exact locations for the tube shaping pulleys, see Fig. 4. They were soldered with SnAg and local heat application on the same tooling on which the liners were conformed.

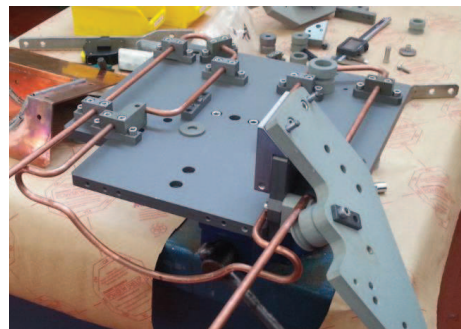

Figure 4: Tooling for shaping of the liner cooling tubes.

TESTS

Low Power Tests

A Vector Networks Analyser (VNA) was used to measure and adjust the cavity by measuring its s parameters. This technique was used for the adjustment of the coupling factor during the assembly of the input coupler by rotation (with a target of 1 for minimum reflected power with negligible beam current). After that, measurements of resonant frequency, Q factor, coupling factor, and tuners regulation range were done. The pickup calibration parameter and the cavity R_{shunt} were calculated by com-

binning the VNA measurements with the R_{shunt}/Q figure obtained from the finite element 3D model. Table 1 summarizes these results.

Table 1: Low Power Measurements Under Vacuum

Minimum frequency (plungers up)	60.150 MHz
Maximum frequency (plungers down)	60.375 MHz
Q_L	2,333
Q_0	4,763
Coupling factor	1.042
R_{shunt}	303 k Ω
Expected forward power at 60 kV	5.93 kW
Expected pickup power at 60 kV	32.0 dBm

The results are as expected from the simulations. Actual Q_0 is just 9.3 % worse than calculated one. The factors that are not included in the simulations (contacts, surface impurities, roughness, etc.) usually account for a 20-30% decrease in Q_0 , so we can say that the effort put to reduce those effects has given an excellent result.

High Power Tests and Conditioning

The high power tests were done at ALBA synchrotron RF lab. Initially a bake-out under vacuum was performed for 13 days with a cavity temperature between 90 and 110 °C, in which vacuum pressure in cold condition was reduced by more than two orders of magnitude, from 2×10^{-6} to 6×10^{-8} mbar.

The RF power was provided by a solid state amplifier manufactured by BTESA under CIEMAT specifications, capable of providing up to 8 kW by combining the power from four 2 kW modules.

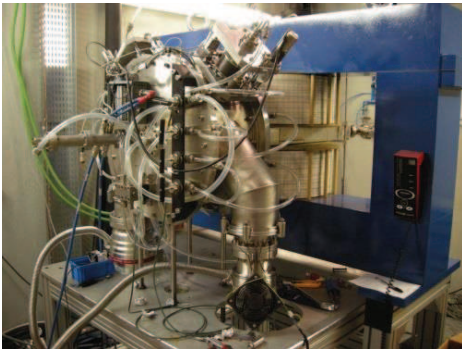

Figure 5: Cavity and magnet at the RF laboratory bunker.

As the acceleration gap of the cavity will be working under a huge magnetic field (4 T) the conditioning was performed with a magnet providing some magnetic field (1.1 T) at the centre of the cavity, see Fig. 5. The cavity showed better behaviour (less multipacting activity, lower arcs rate and reduced conditioning time) when this magnetic field was present, showing the big influence that it has on the cavity and the convenient decision that doing the conditioning with this magnet was. It was manufactured by ANTEC Magnet Precision Systems.

Conditioning was performed in CW mode for approximately 100 h. Maximum cavity voltage achieved was 67.1 kV with 8.43 kW forward power, pushing the limits

of the amplifier capability. Vacuum pressure during conditioning was 1×10^{-8} mbar at low cavity load, with a 7×10^{-8} mbar peak at around 42 kV, indicating a high multipacting activity point. From 55 to 67 kV vacuum level increases up to 2×10^{-8} , indicating in this case a higher outgassing rate due to field emission electrons.

A fast interlock system governed by the reverse power signal detected the arcs and stopped immediately the RF power. About 100 arcs were produced during the conditioning, normally showing an improvement in the cavity behaviour (decreasing arc rate with time for a constant cavity voltage). The arc rate at nominal conditions after the conditioning was below 1 arc/hour.

The cavity was also tested for 25 hours with a 10 sccm H_2 flow inserted into the cavity through the ion source slit, simulating the worse vacuum conditions that will be present at the real cyclotron, especially in the central region. The vacuum was between 8×10^{-5} mbar and 1×10^{-4} mbar. A voltage of 64 kV was easily reached, showing that the quality of the vacuum is not a major factor for arc production.

CONCLUSION

The cavity for the AMIT cyclotron was successfully fabricated and tested. The performance of the cavity nicely exceeds the target and matches the simulations. Especially relevant is the high voltage that the cavity was able to maintain, which was a serious and critical aspect for this project. It has been shown that careful optimization for minimizing the peak electric field and excellent surface finishing can lead to very good and somehow unexpected results independently of other less important factors like vacuum level, frequency or the voltage itself.

ACKNOWLEDGEMENTS

The authors would like to thank the invaluable contribution of the companies involved in the project and the people in them (ZEHAZ and DMP from EGILE Group, BTESA, ANTEC Magnet Precision Systems, ECOR Research and GALVANO-T).

REFERENCES

- [1] C. Oliver *et al.*, "Optimizing the radioisotope production with a weak focusing compact cyclotron", in *Proc. 20th Int. Conf. on cyclotrons and their applications (CYCLOTRONS'13)*, Vancouver, Canada, Sep. 2013, paper WE4PB03, pp. 429-431.
- [2] D. Gavela *et al.*, "Calculation and design of a RF cavity for a novel compact superconducting cyclotron for radioisotope production (AMIT)", in *Proc. 6th Int. Particle Accelerator Conf. (IPAC'15)*, Richmond, VA, USA, May. 2015, paper WEPMN057, pp. 3055-3057.
- [3] D. Gavela *et al.*, "Fabrication and tests of the re-buncher cavities for the LIPAc deuteron accelerator", in *Proc. 5th Int. Particle Accelerator Conf. (IPAC'14)*, Dresden, Germany, Jun. 2014, paper THPRI051, pp. 3884-3886.