



ACDIV-2017-09

May 2017

1.5 GHz CAVITY DESIGN FOR THE CLIC DAMPING RING AND AS ACTIVE THIRD HARMONIC CAVITY FOR ALBA

B. Bravo, J. Alvarez, A. Salom, F. Ferez - ALBA Synchrotron

Abstract

In a collaboration framework between CERN and ALBA, we are designing a normal conducting active 1.5 GHz cavity which could serve as main RF system for the Damping Ring of CLIC and as an active third harmonic cavity for the ALBA Storage Ring. The third harmonic cavity at ALBA will be used to increase the bunch length in order to improve the beam lifetime and increase the beam stability thresholds. The main advantage of an active third harmonic cavity is that optimum conditions can be reached for any beam current. This paper presents the preliminary design of this cavity: an active, normal conducting cavity tuned at 1.5 GHz based on the 500 MHz European Higher Order Mode (HOM) damped normal conducting with nose cones using ridged circular waveguides for HOM damping. Electromagnetic simulations, mechanical and thermal stress analysis will be presented together with the calculations on beam stability improvement due to the third harmonic system..

Accelerator Division
Alba Synchrotron Light Source
c/ de la Llum, 2-26
08290 Cerdanyola del Valles, Spain

1.5 GHz CAVITY DESIGN FOR THE CLIC DAMPING RING AND AS ACTIVE THIRD HARMONIC CAVITY FOR ALBA

B.Bravo, J.Alvarez, A.Salom, F. Ferez, CELLS - ALBA, Cerdanyola del Vallès, Spain

Abstract

In a collaboration framework between CERN and ALBA, we are designing a normal conducting active 1.5 GHz cavity which could serve as main RF system for the Damping Ring of CLIC and as an active third harmonic cavity for the ALBA Storage Ring. The third harmonic cavity at ALBA will be used to increase the bunch length in order to improve the beam lifetime and increase the beam stability thresholds. The main advantage of an active third harmonic cavity is that optimum conditions can be reached for any beam current. This paper presents the preliminary design of this cavity: an active, normal conducting cavity tuned at 1.5 GHz based on the 500 MHz European Higher Order Mode (HOM) damped normal conducting with nose cones using ridged circular waveguides for HOM damping. Electromagnetic simulations, mechanical and thermal stress analysis will be presented together with the calculations on beam stability improvement due to the third harmonic system.

INTRODUCTION

The concept of using a normal conducting 1.5 GHz cavity operated as an active third harmonic for the ALBA Storage Ring and as a main RF system at the Damping Ring of CLIC, is under technical development in the framework of an international collaboration within ALBA and CERN.

In high brightness synchrotron accelerators as ALBA, the beam lifetime is usually dominated by Touschek scattering. One method for increasing the lifetime from Touschek effect without compromising the transverse beam brightness or increasing the beam energy spread is stretching the bunch using a secondary RF system [1]. Also, a higher harmonic cavity can help in damping coherent instabilities through an effect known as Landau damping. Harmonic cavities have been used either for lifetime improvement, curing beam instabilities, or both.

The following Table 1 summarizes the requirements for the design of the third harmonic cavities for ALBA. The total voltage, V_h , and the stable phase between the bunch and the harmonic cavity, ϕ_h , are the optimum values for obtaining an optimum bunch lengthening.

Table 1: Requirements for the Design of the Third Harmonic Cavities (3HC) for ALBA

Frequency	1498.96MHz
Total Voltage	1.1MeV
Φ_h(optimum)	-2.8 degrees
BBU threshold	400 mA
Nominal/Max power dissipated	16/20 kW
Number of cavities	4

ACTIVE OPERATION

Many accelerators use passive third harmonic cavities, in which the voltage is induced by the beam itself. This is an attractive solution as an external generator is not necessary. Nevertheless there are several important advantages of an active cavity as compared to the passive solution such as: the operation near the optimal voltage and phase ($V_h=1.1MV, \phi_h=-2.8$ degrees) can be achieved for any beam current, and the contribution to the antidamping impedance for the Robinson stability is neglectible.

The operating point of the active third harmonic system at ALBA will be $\phi_h=0$, i.e the power lost by the beam passing through the cavity will be $P_{beam}=0$. All other conditions will remain the same as in the optimum case [2]. The theoretical calculations (see Table 2) show that the consequence of not operating at the optimum phase results in a bunch length very close to the optimum conditions. For carrying out the calculations it was considered 4 cavities that provide 1.1 MV and shunt impedance, $R_s=2.4M\Omega$. This operating point will allow implementing a simple control loop, keeping the cavity forward power (P_{forw}) constant. With no beam, the transmitter drives the cavity at resonance through a near matched input loop. As beam is injected, the tuning loop compensates for the reactive beam loading.

Table 2: Comparison between the Forward Power Per Cavity, the power lost by the beam and the bunch length when $\phi_h=0$ and $\phi_h=-2.8$.

ϕ_h	P_{forw} ($i_b=0$ A)	P_{forw} ($i_b=0.2$ A)	P_{beam} ($i_b=0.2$ A)	Bunch length
-2.8	16 kW	8 kW	-8 kW	$3.3 \sigma_0$
0	16 kW	16 kW	0	$3.7 \sigma_0$

CAVITY DESIGN

The development of the new 1.5 GHz cavity for the ALBA is based on the 500 MHz normal conducting cavity higher order mode (HOM) damped [3]. This cavity is a pill-box with nose cones working at ambient temperature. Attached to the body, there are three ridged circular waveguides (dampers) for HOM damping (see Fig. 1).

The figures of merit for the design of the future cavity are a high shunt impedance and quality factor for the fundamental mode and low HOM impedance.

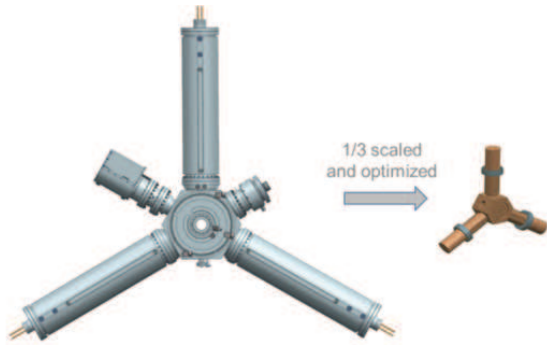

Figure 1: HOM damped cavity vs. scaled and optimized 3HC HOM cavity.

Beam Pipe Aperture

A key feature and a starting element in the design of the cavity is the beam pipe diameter. Since synchrotron radiation and electron beam aperture constrain the beam pipe diameter above a minimum value it is worth to study how to optimise it. The electron beam aperture is determined by the lattice. The synchrotron radiation comes from the dipoles and can impact onto the cavities leading to damaging them. To avoid these problems careful raytracing analysis is done, using an appropriate design of the absorbers and placing them in the system.

In order to determine the beam pipe diameter of the cavity the following steps have been followed: definition of the components and its longitudinal dimensions, definition of the layout of the whole system (see Fig. 2), and finally the realization of raytracing analysis for the worst case elements of the layout (see Fig. 3).

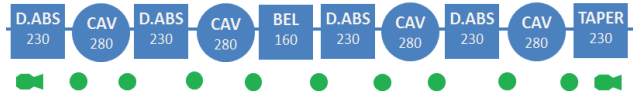

Figure 2: Cavity set-up lay-out with component longitudinal dimensions.

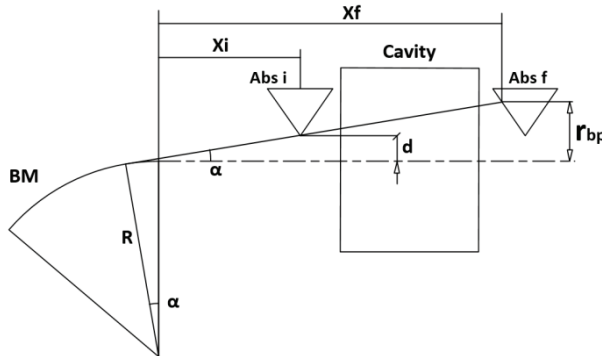

Figure 3: Raytracing schematic.

Figure 3 is a schematic of the components involved in the raytracing to determine the beam pipe diameter. The beam pipe diameter can be expressed by the following formula:

$$D_{BP} = 2 \cdot [d + (X_f - X_i) \cdot \tan \alpha + \gamma] \quad (1)$$

Where the beam pipe diameter (D_{BP}) depends on the longitudinal dimensions of the components, and their position in the long section (X_f, X_i). The distance d is the separation of the distributed absorber tip to the electron beam orbit, and γ is a safety margin of 2 mm, assumed in the calculation.

The conclusion of the analysis is a beam pipe diameter of 46 mm assuming a lay-out system of 4 cavities, protected each of them by a previous distributed absorber. The whole system is around XX meters and is foreseen to be installed in a long section of the ALBA Storage Ring.

Optimization of the Dampers

The HOM energy is coupled by three circular waveguide (dampers). Each waveguide has two ridges to reduce the cut-off frequency. The fundamental mode does not penetrate in the damper, because of the cut-off frequency of the ridged waveguides. The waveguide terminates in a wedge shaped C-48 ferrite load.

The main two objectives that have been followed for the optimization of the dampers have been: Do not couple the fundamental mode and maintain a low reflection response $|S_{11}| < 0.3$ at least up 5 GHz, i.e the monopole cut-off frequency of the beam pipe.

Figure 4 plots the simulated reflection coefficient after the optimization of the damper.

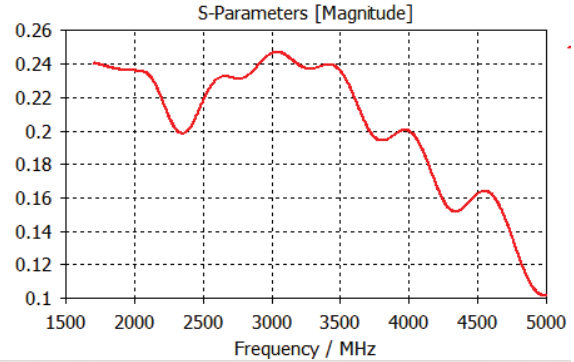

Figure 4: Reflection coefficient of the optimized damper.

Optimization of the Body

The cavity geometry was optimized for high shunt impedance and a high quality factor of the fundamental mode. The final parameters after the optimization are: shunt impedance, $R_s = 1.5 \text{ M}\Omega$, quality factor $Q = 17000$, nominal voltage induced in each cavity $V_{cav} = 215 \text{ kV}$. With this design, five cavities will be needed to reach the optimum bunch lengthening. As, for the moment, it is foreseen to install only four cavities to allow also space for an ID in the long straight, the bunch length will increase to $2\sigma_0$, below the optimum, but realistic

HOM ANALYSIS

The couple bunch instability is a big concern in storing the high current beam for the synchrotron light source. A multi-bunch-filling mode gives rise to instability if a high order mode (HOM) is coupled to a multi-bunch oscillation.

tion mode. The stored beam current can be limited due to this effect.

Using CST microwave studio, it has been analysed the high order modes up to 5 GHz. The simulations plot in the Fig. 5, shows that the impedance of the HOMs is below the threshold. After analysing all the HOM, it was calculated that the maximum power dissipated in the ferrites of each damper will be 115 W. A safety margin of order 3 has been left for this calculation.

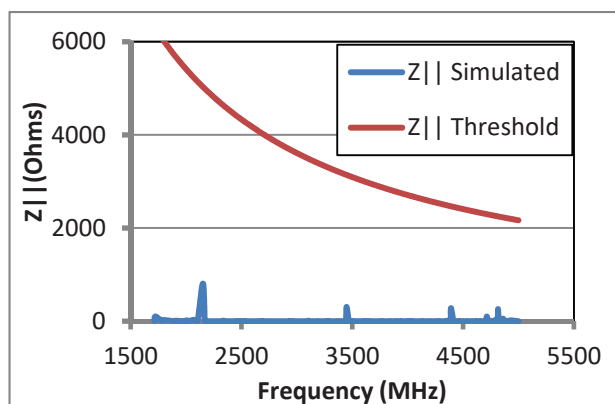

Figure 5: Simulated longitudinal impedance.

CAVITY MECHANICAL DESIGN

Fluid Thermal Simulations

Coupled thermal-fluid simulations have been performed, using Siemens NX as FEA package. The surface heat deposition, calculated with the electromagnetic model, has been imported as a heat load distribution. Flowing through the cavity body, the cavity body lids and dampers, deionised water at 23 °C is used as coolant.

Figure 6 shows the result of temperature distribution in the cavity. In the picture is shown the cavity sectioned making visible the nose cone and the damper ridges. It is precisely in the damper ridge edge where the temperature reaches its maximum value, 66.7 °C.

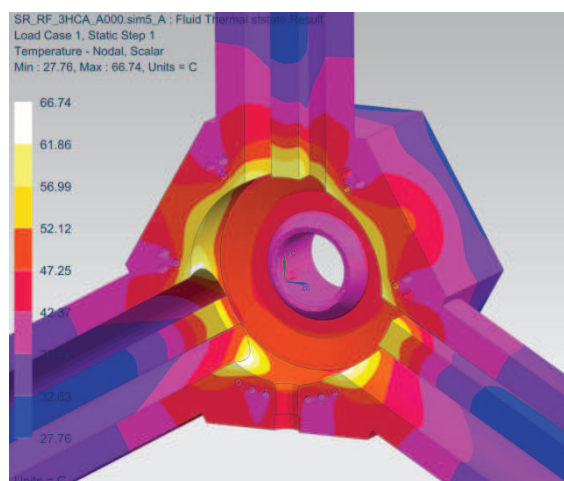

Figure 6: Cavity temperature distribution

Absorber Ferrite Simulations

The HOM absorbers adopted in the 3HC project are in vacuum ferrite absorbers. The design consists of ferrite tiles attached onto a copper wedge cooled by water. An important issue of this design is the problem derived from the difference in the linear thermal expansion between copper ($\Delta l/l = 16.8e-6 \text{ C}^{-1}$) and ZrNi C48 ferrite ($\Delta l/l = 8.0e-6 \text{ C}^{-1}$) [3].

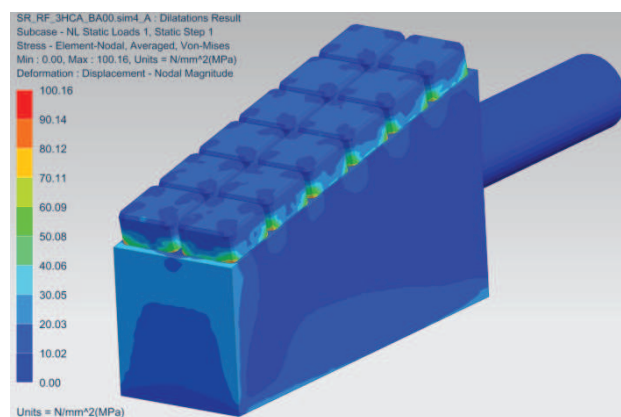

Figure 7. Absorber wedge Von Misses Stresses

After simulating the cooling of the absorber wedge and obtaining its temperature field, a mechanical simulation is performed to calculate dilatations and mechanical stresses in the absorber wedge (see Fig. 7). The weakest element in the absorber are the ferrites which are made of ceramic brittle material. At the bottom corners of the ferrite tiles maximum compression stresses are reached (98 MPa) while at the top of the tiles maximum traction stresses appear (21.2 MPa). Both values are bellow than 200 and 30 MPa, the breakage limits of ZrNi material for compression and traction.

CONCLUSIONS

The 1.5 GHz normal conducting cavity project should yield a substantial improvement in beam lifetime for the ALBA user community and as an effective accelerating cavity for the CLIC project. The adaptation of technology from the 500MHz HOM damped cavity construction project has allowed the development of a robust, efficient and low-risk 1.5 GHz cavity design.

REFERENCE

- [1] A. Hofmann and S. Myers, "Beam dynamics in a double RF system", Proc. of the 11th Int. Conf. on High Energy Acc., ISR-TH-RF/80-26, 1980.
- [2] R. Biscardi, S.L. Kramer, G. Ramirez, "Bunch length control in the NSLS VUV ring", Nuclear Instruments and Methods in Physics Research A 166 (1995) 26-30.
- [3] E. Wehreter, V. Dürr, F. Marhauser, "A ridged circular waveguide ferrite load for cavity HOM damping", Proceedings of EPAC 2006, Edinburgh, Scotland, pp.1280-1282.